

# Mini-Com® TX6A™ 10Gig™ Shielded Jack Modules

## specifications

Category 6A/Class E<sub>A</sub>, 8-position, shielded jack module shall terminate 4-pair, 22 – 26 AWG, 100 ohm shielded twisted pair cable and shall not require use of a punchdown tool. Shielded jack modules shall use a forward motion termination method to optimize performance by maintaining cable pair geometry while eliminating conductor untwist. The termination cap shall be color-coded blue to designate Category 6A performance and shall include a universal label coded for T568A and T568B wiring schemes. The Mini-Com® TX6A™ 10Gig™ Shielded Jack Module must be installed as part of the TX6A™ 10Gig™ Shielded Copper Cabling System to achieve IEEE 10GBASE-T certified performance.



## technical information

<b>Category 6A/Class E<sub>A</sub> channel and component performance:</b>	Exceeds channel requirements of ANSI/TIA-568-C.2 Category 6A and ISO 11801 Class E <sub>A</sub> standards for supporting 10GBASE-T transmission over twisted pair cabling systems in a 4-connector configuration up to 100 meters at swept frequencies 1 to 500 MHz Exceeds component requirements of ANSI/TIA-568-C.2 Category 6A and ISO 11801 Class E <sub>A</sub> standards at swept frequencies 1 to 500 MHz
<b>FCC and ANSI compliance:</b>	Meets all applicable ANSI/TIA-968-A requirements; contacts plated with 50 microinches of gold for superior performance
<b>IEC compliance:</b>	Meets IEC 60603-7
<b>PoE compliance:</b>	Meets IEEE 802.3af and IEEE 802.3at for PoE applications
<b>UL rated:</b>	UL 1863 approved
<b>RoHS compliance:</b>	Compliant
<b>Conductor termination range:</b>	Wire cap compatible with 22 – 26 AWG solid or stranded cable with conductor insulation diameters of 0.060 in. max and overall cable O.D. 0.200 in. to 0.330 in.; marine jack module wire cap compatible with 22 AWG solid or stranded cable with 0.071 in (1.80mm) maximum insulated conductor outside diameter cable

## key features and benefits

<b>100% performance tested</b>	Confidence that each jack module will deliver the critical electrical performance requirements
<b>Utilizes enhanced Giga-TX™ Technology</b>	Optimizes performance by eliminating conductor untwist and reduces installation time and expense
<b>Utilizes Flex technology</b>	Shortens the tuning length of the shielded jack module enabling higher performance
<b>Integral shield</b>	Provides a 360° conductive path to ground shielded jack module with no additional assembly required; shield provides seamless bonding of the jack module with Mini-Com® All Metal Modular Patch Panels
<b>Modular</b>	Shielded jack modules snap in and out of all Mini-Com® Faceplates, Metal Modular Patch Panels and Surface Mount Boxes for easy moves, adds, and changes
<b>True strain relief</b>	Controls cable bend radius for long term installed performance
<b>Individually serialized</b>	Marked with quality control number for future traceability
<b>RJ45 interface</b>	Industry standard interface provides a quick and easy plug and play connection to RJ45 patch cords; backwards compatible
<b>Identification</b>	Can be clearly identified with optional labels and icons for port identification
<b>High density</b>	Able to support 48 ports in 1RU density
<b>Keyed version available</b>	Color-specific keys with positive and negative keying features mechanically and visually distinguish connections to prevent unintentional mating with unlike keyed or non-keyed modular plugs, offering network design flexibility, versatility, accommodating discrete networks for enhanced security
<b>Marine compatible version available</b>	Terminates to TX7000™ Shielded MUD-Resistant Marine Copper Cable (S/FTP), which includes a durable flame-, oil-, UV- and MUD-resistant cable jacket; ideal for use in harsh environments encountered in marine applications including ship and offshore/onshore units
<b>Termination tools (optional)</b>	EGJT termination tool ensures conductors are fully terminated by utilizing a smooth forward motion without impact on critical internal components for maximum reliability; TGJT termination tool ideal for high volume installations
<b>Block out device (optional)</b>	Provides a simple and secure method to control access to data ports while not in use

## applications

Mini-Com® TX6A™ 10Gig™ Shielded Jack Modules are a component of the TX6A™ 10Gig™ Shielded Copper Cabling System. This end-to-end system provides a cost effective medium for ensuring that network bandwidth needs are easily met today and tomorrow. This shielded system provides high performance, excellent EMI suppression and aids in secure data transmission. The Panduit solution helps ensure organizations efficiently and reliably meet their data transmission needs. With certified performance to the

ISO 11801 Class E<sub>A</sub> Edition 2.1, IEEE 802.3an-2006 and ANSI/TIA-568-C.2 Category 6A standards, this system will support high bandwidth applications with data centers and connections to high end workstations such as stacking switches and switch-to-switch links, storage area networks, aggregation of Gigabit Ethernet channels, real-time intensive financial transactions, streaming video, animation, scientific modeling and medical imaging.

[www.panduit.com](http://www.panduit.com)

# PANDUIT®

## SPECIFICATION SHEET

### TX6A™ 10Gig™ Shielded Copper Cabling System

#### Mini-Com® TX6A™ 10Gig™ Shielded Jack Modules

<b>Jack module:</b>	CJS6X88TG*Y
<b>Keyed jack module:</b>	CJSK6X88TG**
<b>Marine jack module:</b>	CJSM6X88TGY†

#### TX6A™ 10Gig™ Shielded Copper Cable†‡

<b>LSZH, U/FTP:</b>	PUFL6X04***-KD
<b>LSZH, F/UTP:</b>	PFL6X04***-CEG
<b>LSZH-3, F/UTP:</b>	PFZ6X04***-CEG
<b>Plenum, F/UTP:</b>	PF6X04***-UG
<b>Riser, U/FTP:</b>	PUFR6X04***-UG

#### TX7000™ Shielded S/FTP MUD-Resistant Marine Copper Cable

<b>LSZH:</b>	PSMD7004+ -LED
<b>Armored LSZH:</b>	PSMDA7004+ -LED

#### TX6A™ 10Gig™ Shielded Patch Cords

<b>Foot lengths:</b>	STP6X^IG
<b>Meter lengths:</b>	STP6X^MIG

#### Mini-Com® Angled Shielded Modular Patch Panels

<b>24-port, 1 RU:</b>	CPA24BLY
<b>48-port, 1 RU:</b>	CPA48HDBL
<b>48-port, 2 RU:</b>	CPA48BLY
<b>72-port, 2 RU:</b>	CPA72BLY

#### Mini-Com® Flat Shielded Modular Patch Panels

<b>24-port, 1 RU:</b>	CP24BLY
<b>48-port, 1 RU:</b>	CP48HDBL
<b>48-port, 2 RU:</b>	CP48BLY
<b>72-port, 2 RU:</b>	CP72BLY

#### Tools and Accessories

<b>Jack module termination tool:</b>	EGJT or TGJT
<b>Wire snipping tool:</b>	CWST
<b>Wire stripping tool:</b>	CJAST
<b>Clean dust cap:</b>	MDC-C
<b>Block out device:</b>	PSL-DCJB-^^
<b>Phone icons:</b>	CIPIW-C++
<b>Data icons:</b>	CIDIW-C++

\*To designate color, add BU (Blue), RD (Red), YL (Yellow), GR (Green) or VL (Violet). For part number CJS6X88TGY (no designation), the color is black.

\*\*To designate color, add suffix BL (Black), BU (Blue), RD (Red), YL (Yellow), GR (Green), or OR (Orange). Each color representing a different keyed configuration. †Offered in black only.

‡To designate color, add suffix BU (Blue) or WH (White). For additional cable colors, contact customer service.

^To designate color, add suffix BL (Black) or WG (Window Gray). For additional cable colors, contact customer service.

^For lengths 3 to 20 feet (one foot increments) and 25, 30, 35, 40 feet, change the length designation in the part number to the desired length. For standard cable colors other than IG (International Gray), substitute the IG suffix with BL (Black), BU (Blue), RD (Red), YL (Yellow), GR (Green), OR (Orange), or VL (Violet). For example, the part number for a blue 15-foot patch cord is STP6X15BU.

^^For lengths 1 to 10 meters (one meter increments) and 1.5, 2.5, 15, 20 meters, change the length designation in the part number to the desired length. For standard cable colors other than IG (International Gray), substitute the IG suffix with BL (Black), BU (Blue), RD (Red), YL (Yellow), GR (Green), OR (Orange), or VL (Violet). For example, the part number for a blue 15-meter patch cord is STP6X15MBU.

^^^To designate color other than Red, add suffix BL (Black), BU (Blue), YL (Yellow), GR (Green), OR (Orange), IW (Off White), or IG (International Gray) at the end of the part number. 10/package.

††To designate color other than IW (Off White), replace IW with EI (Electric Ivory), IG (International Gray), BL (Black), BU (Blue), RD (Red), YL (Yellow), GR (Green), OR (Orange), or VL (Violet) in the part number. 100/package.

†††Note: Other cable shielding types are available. Contact customer service for more information.

Contact customer service for bulk packaged and/or keyed jack modules and patch cords. Panduit recommends installing shielded jack modules in Mini-Com® All Metal Modular Patch Panels. For grounding shielded jack modules not installed in a Mini-Com® All Metal Modular Patch Panel, use the shielded jack module grounding kit, part number CJSK-XY.

# Mini-Com® TX6A™ 10Gig™ Shielded Jack Modules

## Test Results

Mechanical Test	Test Method	Measurement	Test Results
Normal Force	–	Load (grams)	> 100
Vibration	IEC 512-6d	Circuit Resistance (mOhms)	< 40
Shock	IEC 512-6c	Contact Disturbance (microseconds)	< 5
Durability	IEC 512-9a	Circuit Resistance (mOhms)	< 40
Mating/Un-mating	IEC 512-3b	Mating Force (N)	< 20
		Un-mating Force (N)	< 20
Electrical Test	Test Method	Measurement	Test Results
Low Level Circuit Resistance	IEC 512-2a	Resistance (mOhms)	< 20
Dielectric Withstand Voltage	IEC 512-4a	1000 VAC, 1 minute	Passed
Insulation Resistance	IEC 512-3a	Resistance (MOhms)	> 500
Electrical Test	Test Method	Measurement	Test Results
Temperature Life	IEC 512-9b	Circuit Resistance (mOhms)	< 40
Humidity	IEC 512-11c	Circuit Resistance (mOhms)	< 40
Thermal Shock	IEC 512-11d	Circuit Resistance (mOhms)	< 40
Climatic Sequence	IEC 512-11a	Circuit Resistance (mOhms)	< 40
Flowing Mixed Gas Corrosion	IEC 512-11g	Circuit Resistance (mOhms)	< 40

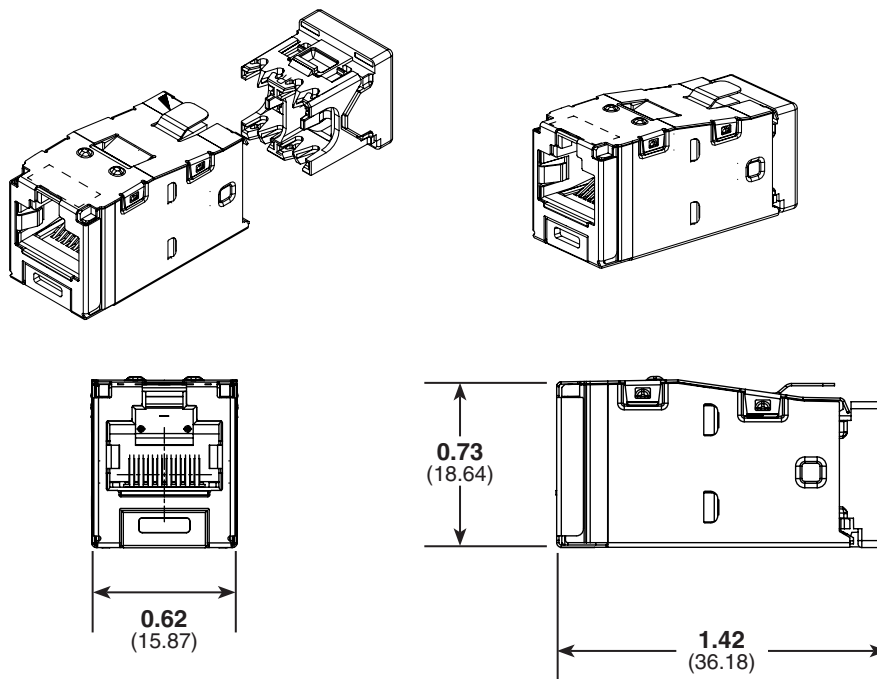

Dimensions are in inches (Dimensions in parenthesis are metric)

### WORLDWIDE SUBSIDIARIES AND SALES OFFICES

PANDUIT CANADA  
Markham, Ontario  
cs-cdn@panduit.com  
Phone: 800.777.3300

PANDUIT EUROPE LTD.  
London, UK  
cs-emea@panduit.com  
Phone: 44.20.8601.7200

PANDUIT SINGAPORE PTE. LTD.  
Republic of Singapore  
cs-ap@panduit.com  
Phone: 65.6305.7575

PANDUIT JAPAN  
Tokyo, Japan  
cs-japan@panduit.com  
Phone: 81.3.6863.6000

PANDUIT LATIN AMERICA  
Guadalajara, Mexico  
cs-la@panduit.com  
Phone: 52.33.3777.6000

PANDUIT AUSTRALIA PTY. LTD.  
Victoria, Australia  
cs-aus@panduit.com  
Phone: 61.3.9794.9020

For a copy of Panduit product warranties, log on to [www.panduit.com/warranty](http://www.panduit.com/warranty)

For more information

Visit us at [www.panduit.com](http://www.panduit.com)

Contact Customer Service by email: [cs@panduit.com](mailto:cs@panduit.com)  
or by phone: 800.777.3300

**PANDUIT**®

© 2015 Panduit Corp.  
ALL RIGHTS RESERVED.  
**COSP230--WW-ENG**  
Replaces WW-COSP58  
3/2015